

SPEED & POSITION
Sensors



High-Performance Sensors for Demanding Environments

Cherry sensors deliver unmatched performance and reliability to a broad range of OEM products. At Cherry, we specialize in economical sensors that are suitable for the most rigorous environments, including extremes of temperature, humidity, thermal shock and vibration. Choose a standard product, or partner with Cherry design engineers as they help you to develop a custom solution.

Customers in the heavy truck, off highway, recreational vehicle, appliance, automotive and medical markets all rely on Cherry sensors for practical designs and durable products.

Cherry offers seven standard sensor product series:

- **MP** — Magnetic Position Sensors
- **DS** — Button Activated Position Sensors
- **GS** — Geartooth Speed Sensors
- **SD** — Geartooth Speed and Direction Sensors
- **VN** — Ferrous Vane Sensors
- **AN** — Angular Position Sensors
- **AS** — Magnetic Actuators and Mating Connectors

Your Total Design Partner

When you need a custom sensor, Cherry provides the design expertise and development tools needed to bring your product to market quickly. We focus on innovation within our core competencies of magnetics, packaging, electronic design, and sealing technologies to assure our customers reliable sensing solutions.

Consider a few of the capabilities Cherry can deliver to your next custom sensor project:

- Using a solid model design concept developed by the customer, Cherry design engineers apply 3D magnetic modeling to ensure appropriate airgaps and magnetic fields are designed in at the start of the project.

- When harsh environments are involved, Cherry recommends appropriate packaging and sealing technology. Our packaging innovations have resulted in sensors that perform under extreme conditions: temperatures up to 150°C, immersion in solvents to IP68, and exposure to salt spray, dust, gravel and repeated thermal shock.
- With Cherry's in-house stereolithography and prototype line, we can quickly provide a highly engineered design.
- We match the latest solid state magnetic sensor technologies to proprietary circuits capable of providing EMI, ESD, EMC and Conducted Immunity resistance tough enough to exceed automotive standards.
- To simulate the wide range of environments that our products experience in the field, Cherry's testing facilities provide concept evaluation, design and product validation, and continuous conformance testing to international standards.
- In-house high-density circuit board assembly assures the quality of our electronics.
- TS-16949 certified factories on multiple continents provide you with advantages in speed, cost and flexibility.

Put Cherry's broad capabilities to work for you in your most demanding applications.

For more information, contact Cherry Electrical Products today.

Phone: 800.285.0773

Web: www.cherrycorp.com



TABLE OF Contents

Magnetic Position Sensors

MP Series

MP1014 Low-Profile	4
MP1001 Threaded Housing	5
MP1005 – 1007 Threaded Housing	6
MP1013 Snap-Fit	7
MP1021 Flange-Mount	8
MP2007 Threaded Housing	9
MP2017 Cylindrical Plastic Housing	10
MP2018 Mini Flange-Mount	11
MP2019 Flange-Mount	12

DS Series

DS Button Activated Position Sensors	13
--------------------------------------	----

Vane Sensors

VN Series

VN1015 Digital Vane Sensor	15
----------------------------	----

Geartooth Speed Sensors

GS Series

GS1001 – 1002 Threaded Housing	16
GS1005 – 1007 Threaded Housing	17
GS1012 Flange Mount	18

Geartooth Speed and Direction Sensors

SD Series

SD1002 – 1012 Speed and Direction	19
-----------------------------------	----

Angular Position Sensors

AN Series

AN1 Intrinsic Linear Angular Position Sensors	20
AN8 Thin Angular Position Sensors	21

Connection/Interface Details

Current Sink Interfacing	22
Actuator Magnets	22
Sensor Operation	23

Custom Sensors

Rugged Rotary Encoder	24
Magnetic Inertial Imbalance Sensor	24
Magnetic Speed and Direction Sensor	24

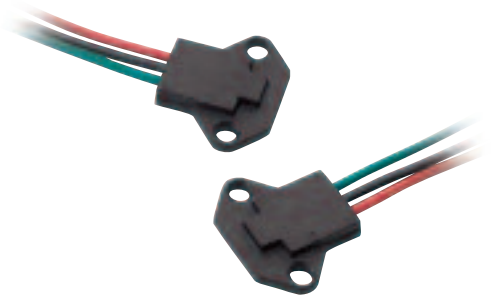

MAGNETIC SENSOR

MP1014 Series



Digital Hall-effect position sensor in low-profile flange-mount housing.

Features

- Capable of millions of operations
- Meets IEC529 IPX5 for water protection
- Reverse Battery Protection to -24VDC
- MP101401 south pole activated unipolar switching
- MP101402 provides highly sensitive unipolar switching
- MP101403 latches in presence of south pole and unlatches in presence of north pole magnet
- RoHS Compliant

Applications

- Door position sensing
- Flow sensing
- Pedal switch

Specifications

Part Number	Operating Voltage Range (VDC)	Supply Current (mA max.)	Output	Output Saturation Voltage (mV max.)	Output Current (mA max.)	Operating Temp Range (°C)	Function	Operate Point Gauss (max.)	Release Point Gauss (min.)
MP101401	4.5 – 24	5.2	3-wire sink	400	20	-40 to 85	Unipolar Switch	185 (south)	60 (south)
MP101402	4.5 – 24	5.2	3-wire sink	400	20	-40 to 85	Unipolar Switch	95 (south)	20 (south)
MP101403	4.5 – 24	5.2	3-wire sink	400	20	-40 to 85	Bipolar Latch	120 (south)	100 (north)

Notes: These sensors require the use of an external pull-up resistor, the value of which is dependent on the supply voltage. See page 22 for recommendations. Pull-up resistor should be connected between output (Green) and Vcc (Red). Unipolar switch output turns low in presence of magnetic south pole. Bipolar latch output latches high in presence of magnetic south poles and latches low in presence of magnetic north pole.

Dimensions inches (mm)

All tolerances ±0.005 (0.13) unless otherwise noted.

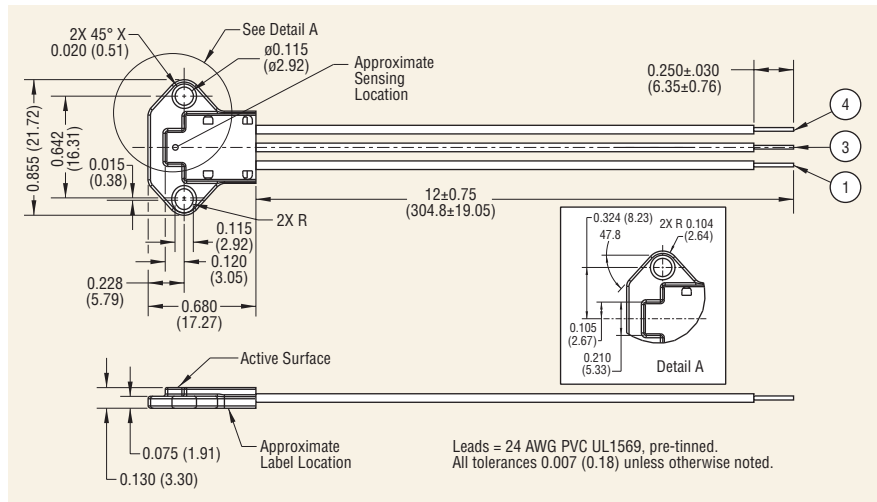

Open Collector Sinking Block Diagram

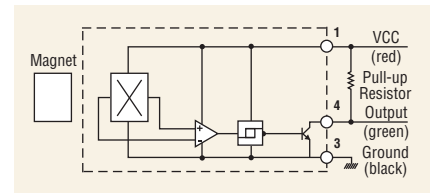

MAGNETIC SENSOR

MP1001 Series



Solid state, magnetic position sensors with electrical immunity protection.

Features

- Stable output over operating temperature range
- Compatible with unregulated power supply
- Reverse battery protected to -24VDC
- Internal circuit protection to IEC529 1000
 - EMI resistant to 10V/m, 30MHz to 1GHz
 - ESD resistant to 4kV (contact discharge)
 - Fast transient resistant to 2kV
 - Conducted immunity resistant to 10VRMS@150kHz to 80MHz
 - EMC compatible 30A/m@50Hz
- Meets IEC529 IP67 for dust and water protection
- South pole activated
- Open collector (sinking or NPN) output can be used with bipolar or cmos logic circuits with suitable pull up resistor
 - Output switches low (off) when the magnetic field at the sensor exceeds the operate point threshold
 - Output switches high (on) when the magnetic field is reduced to below the release point threshold
- RoHS Compliant

Applications

- Safety door
- Power sliding door
- Flow sensing

Specifications

Part Number	Operating Voltage Range (VDC)	Supply Current (mA max.)	Output	Output Saturation Voltage (mV max.)	Output Current (mA max.)	Operating Temp Range (°C)	Storage Temp Range (°C)	Operate Point Gauss (max.)	Release Point Gauss (min.)	Housing	Cable	Connector
MP100101	5 – 24	12	3-wire sink	700	25	-40 to 105	-40 to 105	300	60	SST	—	12mm circular
MP100102	5 – 24	12	3-wire sink	700	25	-40 to 125	-40 to 125	300	60	SST	22 AWG x 1m BBB	—

Notes: These sensors require the use of an external pull-up resistor, the value of which is dependent on the supply voltage. See page 22 for recommendations. Pull-up resistor should be connected between output (Black) and Vcc (Brown).

Dimensions inches (mm)

All tolerances ±0.005 (0.13) unless otherwise noted.

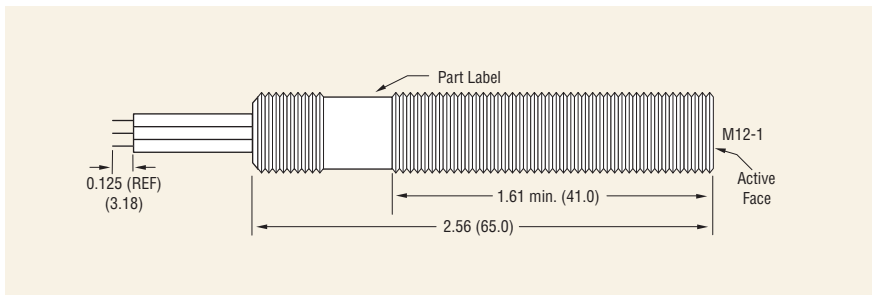

Open Collector Sinking Block Diagram

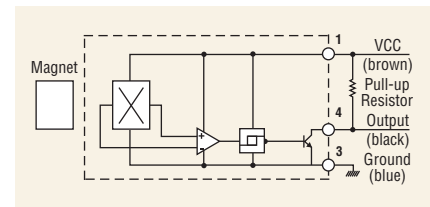

MAGNETIC SENSOR

MP1005–MP1007 Series



Solid state, magnetic position sensors in adjustable, threaded housing.

Features

- Excellent output stability over operating temperature range
- Regulated power supply not required
- Reverse battery protection to -24VDC
- Meets IEC529 IP67 for dust and water protection
- Wire: 20 AWG, tin plated, polyolefin insulation
- Anodized aluminum housing
- South pole activated
- RoHS Compliant

- Open Collector (NPN) output can be used with bipolar or cmos logic circuits with suitable pull up resistor
 - Output switches low (off) when the magnetic field at the sensor exceeds the operate point threshold
 - Output switches high (on) when the magnetic field is reduced to below the release point threshold

Applications

- Limit switch
- Home security
- Door position

Specifications

Part Number	Operating Voltage Range (VDC)	Supply Current (mA max.)	Output	Output Saturation Voltage (mV max.)	Output Current (mA max.)	Operating Temp Range (°C)	Storage Temp Range (°C)	Operate Point Gauss (max.)	Release Point Gauss (min.)	Housing Color	Wires
MP100502	4.75 – 24	12	3-wire sink	700	25	-40 to 125	-40 to 125	300	60	Red	20 AWG x 1m BBB
MP100701	4.75 – 24	16	3-wire sink	700	25	-40 to 105	-40 to 125	300	60	Black	20 AWG x 1m BBB

Notes: These sensors require the use of an external pull-up resistor, the value of which is dependent on the supply voltage. See page 22 for recommendations. Pull-up resistor should be connected between output (Black) and Vcc (Brown).

Dimensions inches (mm)

All tolerances ± 0.005 (0.13) unless otherwise noted.

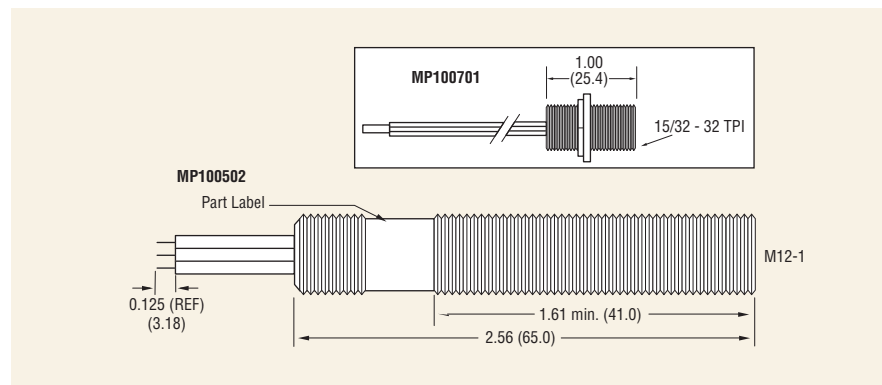

Open Collector Sinking Block Diagram

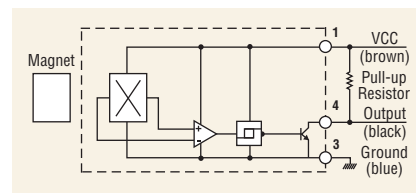

MAGNETIC SENSOR

MP1013 Series



Hall-effect position sensor with convenient snap-fit mounting.

Features

- Solid state reliability
- Excellent output stability over operating temperature range
- Regulated power supply not required
- Meets IEC529 IP67 for dust and water protection
- Open Collector (NPN) output can be used with bipolar switch or CMOS logic circuits with suitable pull up resistor
- MP101301 and MP101302 — unipolar switch
 - Output switches high (on) when the magnetic field is reduced to below the release point threshold
 - Output switches low (off) when the magnetic field at the sensor exceeds the operate point threshold.
- MP101303 — bipolar latch
 - Output latches high (on) in the presence of a south pole
 - Output unlatches (low or off) in the presence of a north pole
- RoHS Compliant

Applications

- Speed sensing
- Door interlock sensing
- Water flow sensing

Specifications

Part Number	Operating Voltage Range (VDC)	Supply Current (mA max.)	Output	Output Saturation Voltage (mV max.)	Output Current (mA max.)	Operating Temp Range (°C)	Storage Temp Range (°C)	Operate Point Gauss (max.)	Release Point Gauss (min.)	Leads	Reverse Battery Protection
MP101301	4.75 – 24	9	3-wire sink	400	25	-40 to 85	-40 to 105	300	60	24 AWG x 150mm	-24VDC
MP101302	4.75 – 24	9	3-wire sink	400	25	-40 to 125	-40 to 125	300	60	24 AWG x 150mm	-24VDC
MP101303	3.5 – 24	4	3-wire sink	500	25	-40 to 85	-40 to 105	45	-45 (latch)	24 AWG x 150mm	None

Notes: These sensors require the use of an external pull-up resistor, the value of which is dependent on the supply voltage. See page 22 for recommendations. Pull-up resistor should be connected between output (Green) and Vcc (Red).

Dimensions inches (mm)

All tolerances ± 0.005 (0.13) unless otherwise noted.

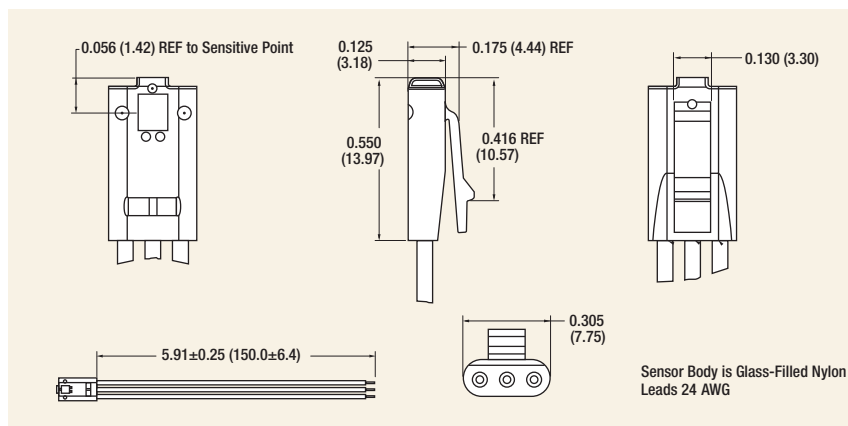

Open Collector Sinking Block Diagram

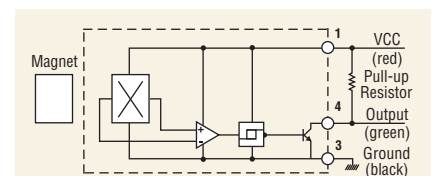

Sensor Pocket

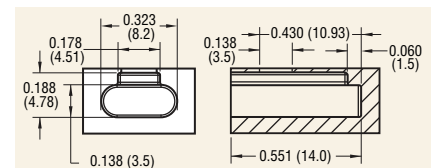

MAGNETIC SENSOR

MP1021 Series



Digital Hall-effect position sensor in plastic flange-mount housing

Features

- Three sensing orientations available in a convenient flange mount housing
- Excellent output stability over operating temperature range
- Compatible with unregulated power supply
- Reverse battery protection to -24VDC
- Meets IEC529 IP67 for dust and water protection
- Open Collector (NPN) output can be used with bipolar switch or CMOS logic circuits with suitable pull up resistor
- MP102101-03 — north pole activated unipolar switch
 - Output switches high (on) when the magnetic field is reduced to below the release point threshold
- MP102104-06 — bipolar latch
 - Output latches high (on) in the presence of a north pole
 - Output unlatches (low or off) in the presence of a south pole
- RoHS Compliant

Applications

- Interrupt switch
- Limit switch
- Door position

Specifications

Part Number	Operating Voltage Range (VDC)	Supply Current (mA max.)	Output	Output Saturation Voltage (mV max.)	Output Current (mA max.)	Operating Temp Range (°C)	Function	Operate Point Gauss (max.)	Release Point Gauss (min.)	Sensing Location
MP102101	4.5 – 24	12	3-wire sink	500	25	-40 to 85	Switch	400 (north)	195 (north)	A
MP102102	4.5 – 24	12	3-wire sink	500	25	-40 to 85	Switch	400 (north)	195 (north)	B
MP102103	4.5 – 24	12	3-wire sink	500	25	-40 to 85	Switch	400 (north)	195 (north)	C
MP102104	4.5 – 24	12	3-wire sink	500	25	-40 to 85	Latch	60 (north)	60 (south)	A
MP102105	4.5 – 24	12	3-wire sink	500	25	-40 to 85	Latch	60 (north)	60 (south)	B
MP102106	4.5 – 24	12	3-wire sink	500	25	-40 to 85	Latch	60 (north)	60 (south)	C

Notes: These sensors require the use of an external pull-up resistor, the value of which is dependent on the supply voltage. See page 22 for recommendations. Pull-up resistor should be connected between output (Green) and Vcc (Red).

Dimensions inches (mm)

All tolerances ± 0.005 (0.13) unless otherwise noted.

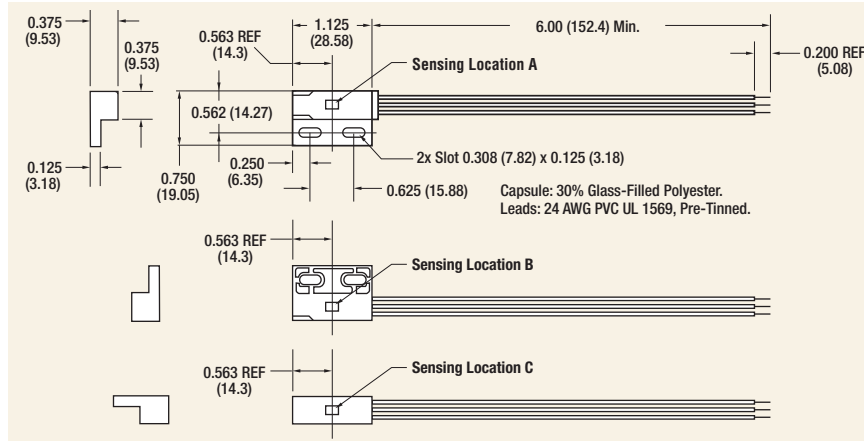

Open Collector Sinking Block Diagram

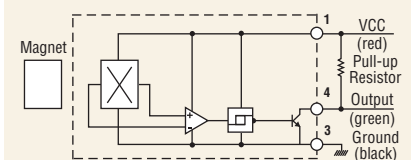

MAGNETIC SENSOR

MP2007 Series



Reed-based magnetic position sensor in aluminum threaded housing.

Features

- Zero power consumption
- Suitable for DC and AC circuits
- Contacts hermetically sealed for long life
- RoHS Compliant

Specifications

Part Number	Contact Form	Power Rating (W max.)	Switching Voltage (AC/DC max.)	Breakdown Voltage (VDC min.)	Switching Current (Amps max.)	Contact Resistance (Ohms max.)	Operating Temp Range (°C)	Operate Time (msec typical)
MP200701	SPST-NO Form A	10	AC 100 DC 100	200	0.5	0.100	-40 to 105	0.3
MP200702	SPST-NC Form B	3	AC 30 DC 30	200	0.2	0.100	-40 to 105	1.0
MP200703	SPDT-CO Form C	3	AC 30 DC 30	200	0.2	0.100	-40 to 105	1.0

Dimensions inches (mm)

All tolerances ±0.005 (0.13) unless otherwise noted.

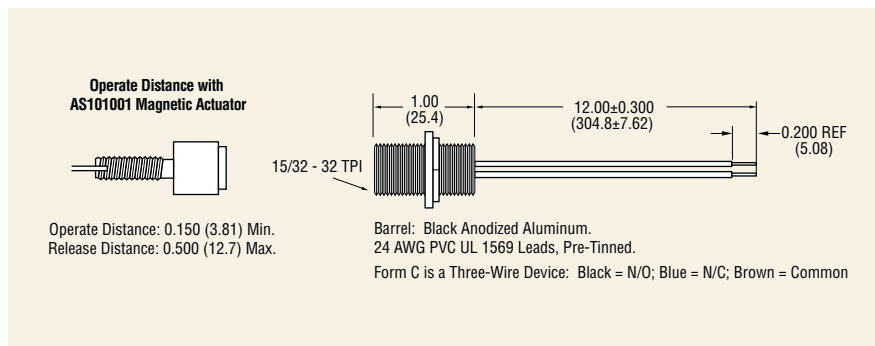

MAGNETIC SENSOR IN CYLINDRICAL PLASTIC HOUSING

MP2017 Series



Reed-based magnetic sensor encapsulated in smooth plastic barrel.

Features

- Hermetically sealed contacts for long life
- Zero power consumption
- Available in a variety of standard contact configurations
- Resistant to moisture and dirt
- A standard magnetic actuator is available in the same housing (Cherry part number AS201701)
- RoHS Compliant

Specifications

Part Number	Contact Form	Power Rating (W max.)	Switching Voltage (AC/DC max.)	Breakdown Voltage (VDC min.)	Switching Current (Amps max.)	Contact Resistance (Ohms max.)	Operating Temp Range (°C)	Operate Time (msec typical)
MP201701	SPST-NO Form A	10	AC 100 DC 100	200	0.5	0.100	-40 to 105	0.3
MP201702	SPST-NC Form B	3	AC 30 DC 30	200	0.2	0.100	-40 to 105	1.0
MP201703	SPDT-CO Form C	3	AC 30 DC 30	200	0.2	0.100	-40 to 105	1.0

Dimensions inches (mm)

All tolerances ± 0.005 (0.13) unless otherwise noted.

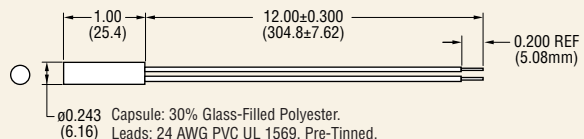

Operate Distance with AS201701 Magnetic Actuator



Operate Distance: 0.150 (3.81) Min.
Release Distance: 0.500 (12.7) Max.

MAGNETIC SENSOR

MP2018 Series



Reed-based magnetic position sensor in plastic flange-mount package.

Features

- Contacts hermetically sealed for long life
- Zero power consumption
- Resistant to moisture and dirt
- A standard magnetic actuator is available in the same housing (Cherry part number AS201801)
- RoHS Compliant

Specifications

Part Number	Contact Form	Power Rating (W max.)	Switching Voltage (AC/DC max.)	Breakdown Voltage (VDC min.)	Switching Current (Amps max.)	Contact Resistance (Ohms max.)	Operating Temp Range (°C)	Operate Time (msec typical)
MP201801	SPST-NO Form A	10	AC 100 DC 100	200	0.5	0.100	-40 to 105	0.3
MP201802	SPST-NC Form B	3	AC 30 DC 30	200	0.2	0.100	-40 to 105	1.0

Dimensions inches (mm)

All tolerances ±0.005 (0.13) unless otherwise noted.

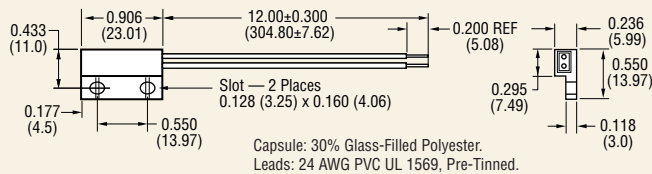

Operate Distance with AS201801 Magnetic Actuator

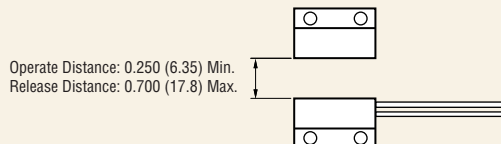

MAGNETIC SENSOR

MP2019 Series



Reed-based magnetic position sensor in plastic flange-mount package.

Features

- Immune to hostile environments
- Contacts hermetically sealed for long life
- Suitable for DC and AC circuits
- Zero power consumption
- A standard magnetic actuator is available in the same housing (Cherry part number AS201901)
- RoHS Compliant

Specifications

Part Number	Contact Form	Power Rating (W max.)	Switching Voltage (AC/DC max.)	Breakdown Voltage (VDC min.)	Switching Current (Amps max.)	Contact Resistance (Ohms max.)	Operating Temp Range (°C)	Operate Time (msec typical)
MP201901	SPST-NO Form A	10	AC 100 DC 100	200	0.5	0.100	-40 to 105	0.3
MP201902	SPST-NC Form B	3	AC 30 DC 30	200	0.2	0.100	-40 to 105	1.0
MP201903	SPDT-CO Form C	3	AC 30 DC 30	200	0.2	0.100	-40 to 105	1.0

Dimensions inches (mm)

All tolerances ±0.005 (0.13) unless otherwise noted.

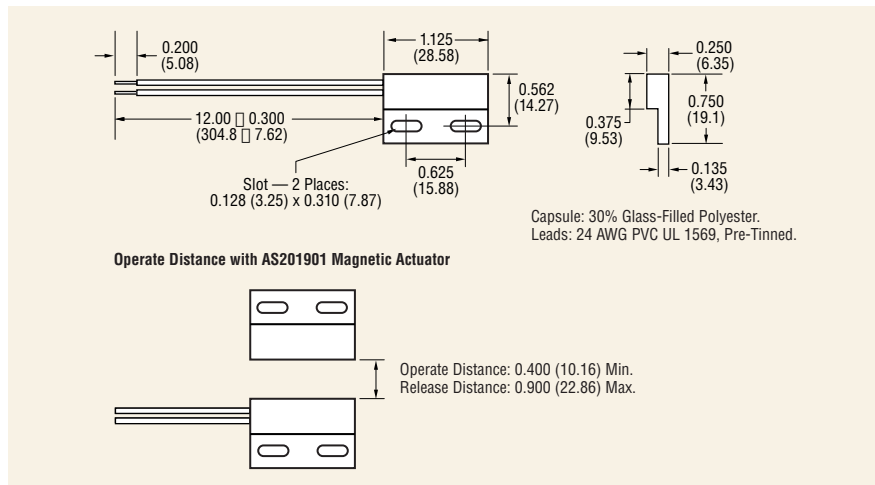

BUTTON ACTIVATED POSITION SENSOR

DS Series



Solid State Sensor

Features

- Fits mounting dimensions of popular snap-action switches
- Tested to more than 10 million operations
- High ratio and standard ratio actuator position
- Available with lever, roller, and simulated roller actuators
- Solid state sinking output using Half effect technology
- UL recognized
- RoHS compliant

Applications

- Pedal position sensing
- Door/lid interlock
- Joystick position sensing
- End-of-Travel sensing

Material Specifications

- Case, cover, actuating button: Thermoplastic Polyester (PBT) UL 94 V-0

Specifications

Part Number	Supply Voltage (VDC)	Supply Current (mA max.@25°C)	Output Type	Output Current (mA max.)	Sensor State Button (button at rest position)	Operating Temp Range	Storage Temp Range
DS Series	4.5 to 24	15	Sink	20	Normally Off	-40° to 85°C	-40° to 150°C

Notes: These sensors require the use of an external pull-up resistor, the value of which is dependent on the supply voltage. See page 22 for recommendations. Pull-up resistor should be connected between output and Vcc.

Dimensions inches (mm)

All tolerances ± 0.005 (0.13) unless otherwise noted.

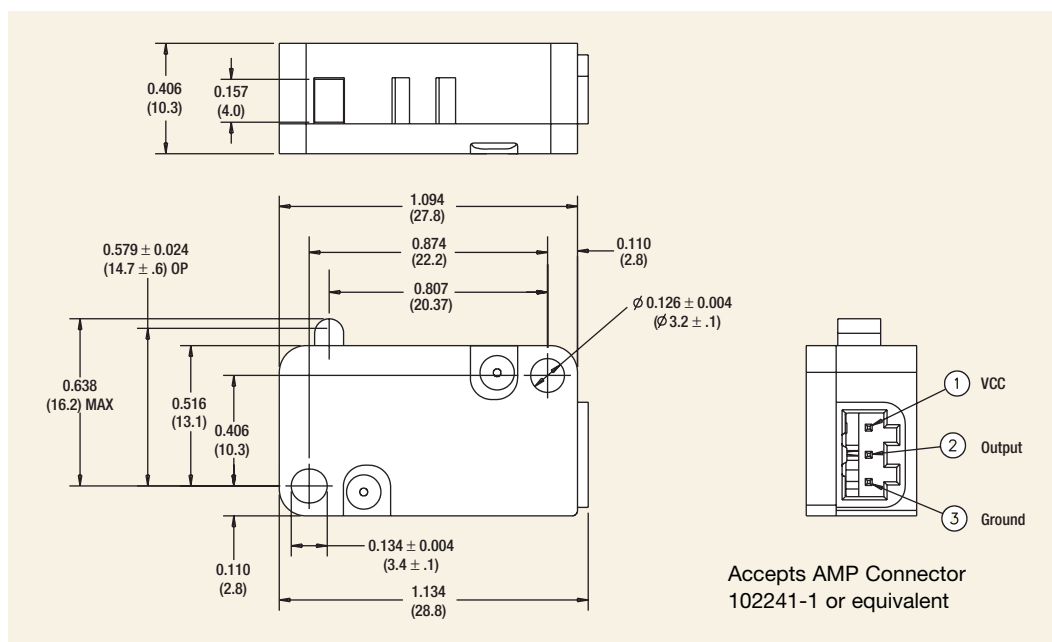

BUTTON ACTIVATED POSITION SENSOR

DS Series *(continued)*

Specifications

Part Number	Lever Style	Lever Actuation Length (inch / mm)	Lever Activation Ratio	Max Pretravel (inch / mm)	Operate Point (inch / mm)	Operate Point Tolerance (+/-inch, +/-mm)	Min Overtravel (inch / mm)	Max Movement Differential (inch / mm)	Max Operating Force (g)
DS1101AA	n/a	n/a	n/a	0.06 1.5	0.58 14.7	0.02 0.6	0.04 1.0	0.01 0.2	84
DS1101JA	SS Leaf	0.87 22.0	Std	0.08 2.1	0.60 15.2	0.03 0.7	0.04 1.0	0.01 0.2	84
DS1101KA	SS Leaf	1.04 26.5	High	0.14 3.5	0.60 15.2	0.05 1.2	0.07 1.7	0.02 0.5	53
DS1101JD	SS Leaf	1.40 35.7	Std	0.17 4.3	0.60 15.2	0.06 1.4	0.08 2.1	0.02 0.5	43
DS1101KD	SS Leaf	1.58 40.2	High	0.28 7.1	0.60 15.2	0.09 2.4	0.14 3.6	0.03 0.8	26
DS1101JJ	SS Leaf	2.34 59.4	Std	0.32 8.1	0.60 15.2	0.11 2.7	0.16 4.0	0.04 0.9	23
DS1101KJ	SS Leaf	2.52 63.9	High	0.53 13.5	0.60 15.2	0.18 4.5	0.27 6.7	0.06 1.5	14
DS1101RA	Roller	0.81 20.5	Std	0.07 1.8	0.81 20.6	0.02 0.6	0.04 0.9	0.01 0.2	99
DS1101TA	Roller	1.0 25.0	High	0.12 3.1	0.81 20.6	0.04 1.0	0.06 1.5	0.01 0.3	59
DS1101SC	Simulated Roller	1.29 32.7	Std	0.15 3.8	0.73 18.5	0.05 1.3	0.07 1.9	0.02 0.4	48
DS1101UC	Simulated Roller	1.47 37.2	High	0.25 6.3	0.73 18.5	0.08 2.1	0.12 3.1	0.03 0.7	29

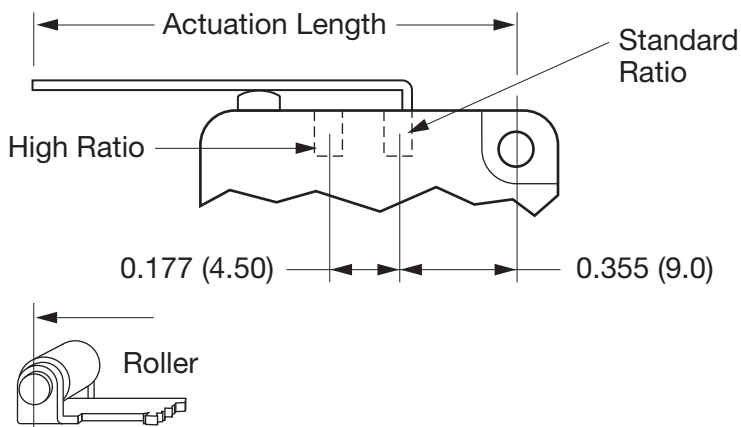

DIGITAL VANE SENSOR

VN1015 Series

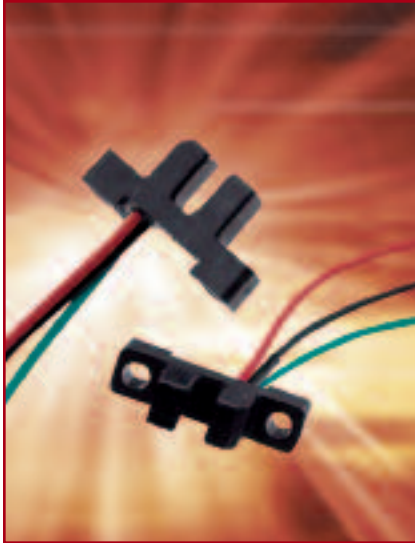

Magnetically activated digital vane sensor in a rugged, overmolded plastic housing with three pins or 3-wire flying leads.

Features

- Available in two operating temperature ranges
- Immune to moisture and dust
- Reliable and repeatable
- No mechanical contacts to wear out
- Operates from 4.5 to 24VDC
- Reverse battery protection to -24VDC
- RoHS Compliant
- Open collector (sinking or NPN) output can be used with bipolar or CMOS logic circuits with suitable pull up resistor
- Sensor body material: glass-filled polyester
- Recommended vane parameters: low carbon material at least 0.040" thick, should penetrate to a depth <0.120" from bottom of sensor slot.
- 25 khz maximum operating speed

Specifications

Part Number	Operating Voltage Range (VDC)	Supply Current (mA max.)	Output	Output Saturation Voltage (mV max.)	Output Current (mA max.)	Operating Temp Range (°C)	Storage Temp Range (°C)	Termination
VN101501	4.5 – 24	6	3-pin sink	400	25	-40 to 85	-40 to 85	pins
VN101502	5.0 – 24	6	3-pin sink	400	25	-40 to 125	-40 to 125	pins
VN101503	4.5 – 24	6	3-wire sink	400	25	-40 to 85	-40 to 85	24 AWG x 150mm leads
VN101504	5.0 – 24	6	3-wire sink	400	25	-40 to 125	-40 to 125	24 AWG x 150mm leads

Notes: These sensors require the use of an external pull-up resistor, the value of which is dependent on the supply voltage. See page 22 for recommendations. Pull-up resistor should be connected between output (Green) and Vcc (Red).

Dimensions inches (mm)

All tolerances ± 0.005 (0.13) unless otherwise noted.

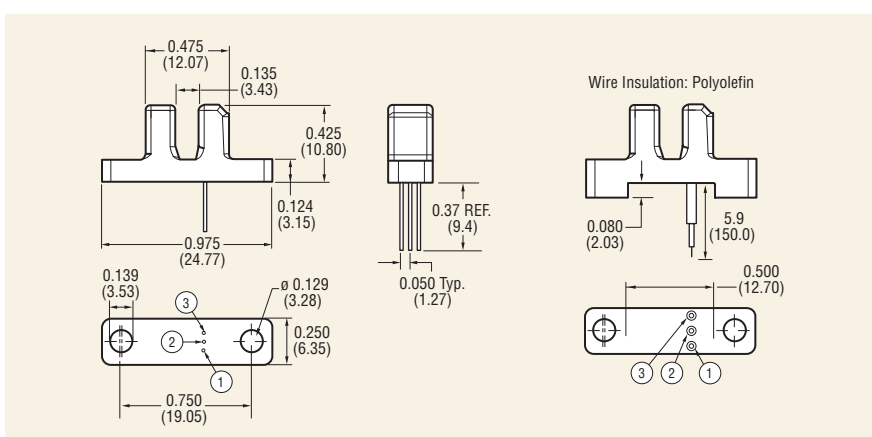

Open Collector Sinking Block Diagram

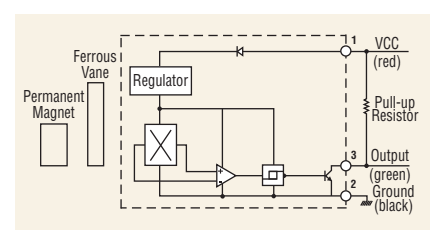

GEARTOOTH SPEED SENSOR

GS1001–GS1002 Series



Circuit-protected, Hall-effect geartooth speed sensor with adjustable stainless steel housing.

Features

- Senses motion of ferrous geartooth targets
- Near zero speed sensing capability
- Immune to rotational alignment
- 10 bit dynamic threshold detection offers
 - Automatically adjusting magnetic range
 - Self compensating to target geometry
 - Immune to target run out
- Compatible with unregulated power supply
- Reverse battery protected to -24VDC
- Internal circuit protection to IEC529 1000
 - EMI resistant to 10V/m, 30MHz to 1GHz
 - ESD resistant to 4kV (contact discharge)
 - Fast transient resistant to 2kV
- Conducted immunity resistant to 10VRMS@150kHz to 80MHz
- EMC compatible 30A/m@50Hz
- Meets IEC529 IP67 for dust and water protection
- Cable version: 22 AWG, tin plated with drain wire and polyolefin insulation
- Connector version: M12 integral connector meets IEC 60947-5-2 for low voltage devices
- Stainless steel housing

Applications

- CNC machine tools
- Transmission speed
- Industrial feedback control

Specifications

Part Number	Operating Voltage Range (VDC)	Supply Current (mA max.)	Output	Output Saturation Voltage (mV max.)	Output Current (mA max.)	Operating Temp Range (°C)	Storage Temp Range (°C)	Thread	Barrel Length	Cable	Connector
GS100101	4.5 – 24	6	sink	700	25	-40 to 105	-40 to 105	M12-1	65mm	—	12mm circular
GS100102	4.5 – 24	6	sink	700	25	-40 to 125	-40 to 125	M12-1	65mm	22 AWG x 1m BBB	—
GS100201	4.5 – 24	6	sink	700	25	-40 to 105	-40 to 105	M18-1	65mm	—	12mm circular
GS100202	4.5 – 24	6	sink	700	25	-40 to 125	-40 to 125	M18-1	65mm	22 AWG x 1m BBB	—

Notes: These sensors require the use of an external pull-up resistor, the value of which is dependent on the supply voltage. See page 22 for recommendations. Pull-up resistor should be connected between output and Vcc.

Dimensions inches (mm)

All tolerances ±0.005 (0.13) unless otherwise noted.

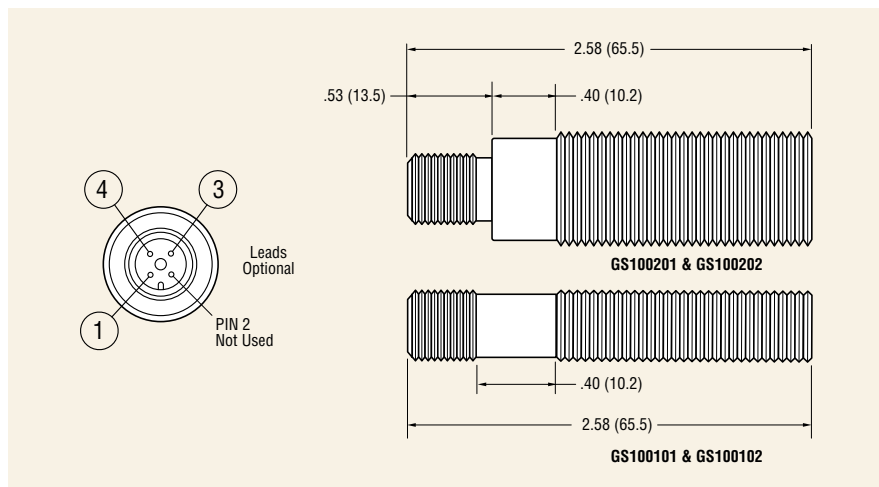

Open Collector Sinking Block Diagram

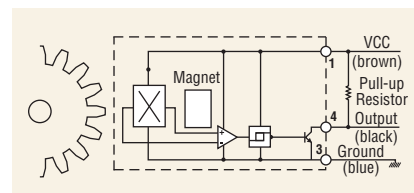

GEARTOOTH SPEED SENSOR

GS1005 – GS1007 Series



Hall-effect geartooth speed sensor with adjustable aluminum housing.

Features

- Senses motion of ferrous geartooth targets
- Near zero speed sensing capability
- Immune to rotational alignment
- 10 bit dynamic threshold detection offers
 - Automatically adjusting magnetic range
 - Self compensating to target geometry
 - Immune to target run out
- Compatible with unregulated power supply
- Reverse battery protected to -24VDC
- Meets IEC529 IP67 for dust and water protection
- Discrete wire version: 20 AWG, tin plated, polyolefin insulation

- Connector version: M12 integral connector meets IEC 60947-5-2 for low voltage devices
- Hard coat anodized aluminum housing

Applications

- Exercise equipment
- Food processing equipment
- Speedometer

Specifications

Part Number	Operating Voltage Range (VDC)	Supply Current (mA max.)	Output	Output Saturation Voltage (mV max.)	Output Current (mA max.)	Operating Temp Range (°C)	Storage Temp Range (°C)	Thread	Barrel Length	Leads	Connector
GS100501	4.5 – 24	6	sink	400	25	-40 to 105	-40 to 105	M12-1	65mm	—	12mm circular
GS100502	4.5 – 24	6	sink	400	25	-40 to 125	-40 to 125	M12-1	65mm	20 AWG x 1m BBB	—
GS100701	4.5 – 24	6	sink	400	25	-40 to 125	-40 to 125	15/32" – 32	1.00"	20 AWG x 1m BBB	—

Notes: These sensors require the use of an external pull-up resistor, the value of which is dependent on the supply voltage. See page 22 for recommendations. Pull-up resistor should be connected between output (Black) and Vcc (Brown).

Dimensions inches (mm)

All tolerances ± 0.005 (0.13) unless otherwise noted.

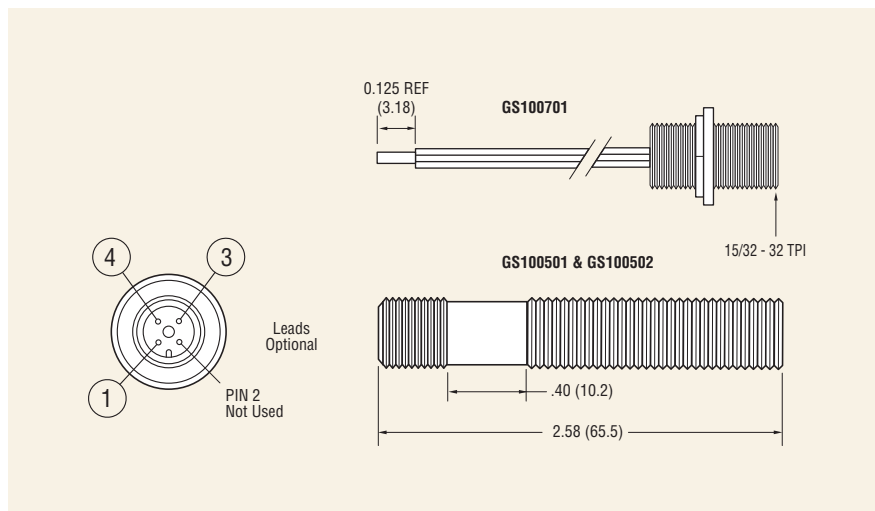

Open Collector Sinking Block Diagram

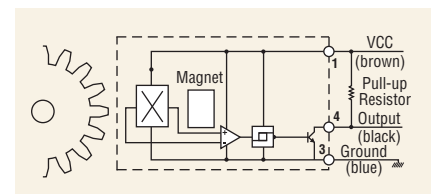

GEARTOOTH SPEED SENSOR

GS1012 Series



Flange mount gear sensor rated to 150°C.

Features

- Capable of operating up to 150°C
- Sealed design exceeds IEC60529 IP67 standard for immersion
- Resistant to fuels, solvents, and lubricants associated with engines, transmissions, brakes and chassis systems
- Easily customizable connector orientation
- ESD resistant to 15kV (contact discharge)
- Operates at arbitrarily low speeds
- Mating connector Delphi 12162280

Applications

- Transmission speed
- Wheel speed
- Engine speed
- Anti-lock braking systems

Open Collector Sinking Block Diagram

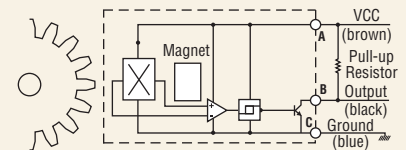

Specifications

Part Number	Operating Voltage Range (VDC)	Supply Current (mA max.)	Output	Output Saturation Voltage (mV max.)	Output Current (mA max.)	Operating Temp Range (°C)	Storage Temp Range (°C)	Leads	Connector
GS101205	5.0 – 30	6	sink	600	25	-40 to 150*	-55 to 150	—	Delphi**

Notes: These sensors require the use of an external pull-up resistor, the value of which is dependent on the supply voltage. See page 22 for recommendations. Pull-up resistor should be connected between output and Vcc.

*For continuous operation at 150°C, supply voltage should be limited to 5.5V max.

**Delphi 12162280

Dimensions inches (mm)

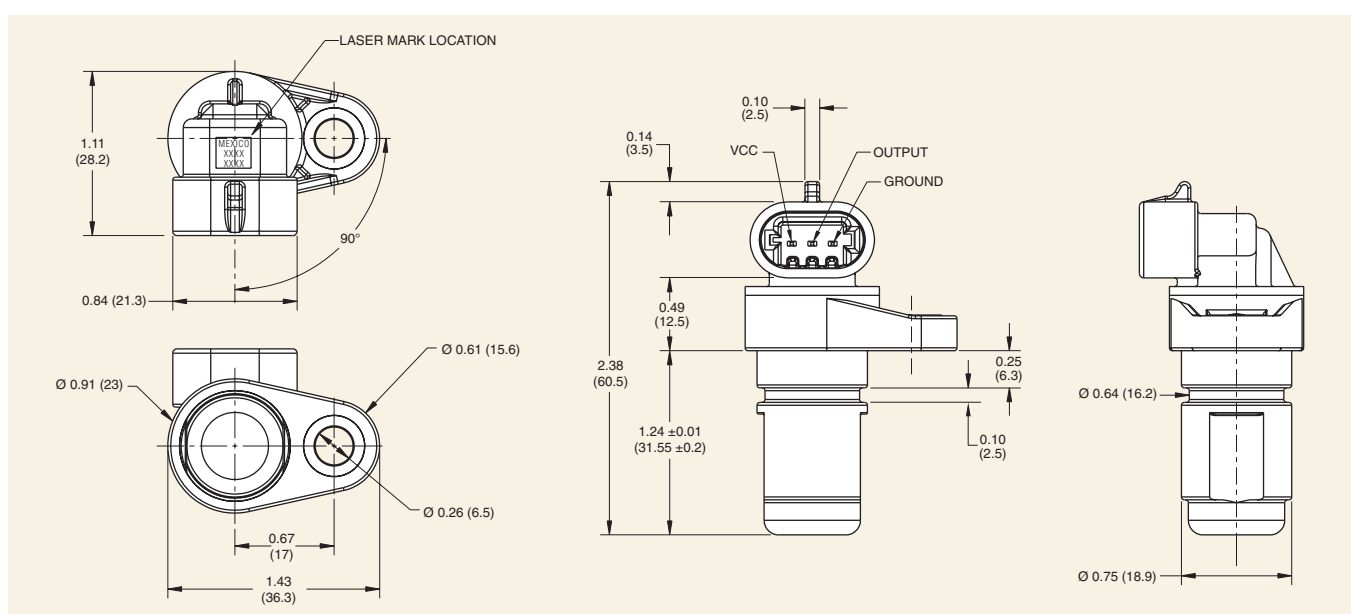

GEARTOOTH SPEED AND DIRECTION SENSOR

SD1002 – SD1012 Series



Hall-effect gear tooth speed and direction sensor with adjustable aluminum or flange-mount plastic housing.

Features

- Sense speed and direction of ferrous gear tooth targets
- Plastic flange mount sensor rated to 125°C
- Near zero speed sensing capability
- Capable of 8000+Hz target speed
- Locating mark provided to assure correct rotational alignment
- 10 bit dynamic threshold detection offers:
 - Automatically adjusting magnetic range
 - Self compensating to target geometry
 - Immune to target run out
- Compatible with unregulated power supply
- Reverse battery protected to -30VDC
- Internal circuit protection to IEC529 1000
 - EMI resistant to 10V/m, 30MHz to 1GHz
 - ESD resistant to 4kV (Contact discharge)
- Fast transient resistant to 2kV
- Conducted immunity resistant to 10VRMS@150kHz to 80MHz
- EMC compatible 30A/m @ 50 Hz
- Meets IEC60529 IP67 for dust and water protection
 - Integral Connector version: 4-pin Delphi Metri Pack 150.2 No. 12162833. Mates with Terminal No. 12124075.
 - Discrete wire version: 20 AWG, PVC insulation, UL1007/1569

Application

- Wheel speed and direction
- Transmission speed and direction
- Hoist speed and direction

Specifications

Part Number	Operating Voltage Range (VDC)	Supply Current (mA max.)	Output	Output Saturation Voltage (mV max.)	Output Current (mA max.)	Operating Temp Range (°C)	Storage Temp Range (°C)	Housing Material
SD100203	4.75 – 24	20	sink	1000	20	-40 to 85	-40 to 85	Aluminum
SD101201	4.75 – 24	20	sink	1000	20	-40 to 125	-40 to 125	Plastic

Notes: SD101201 uses Delphi Metri-Pack 150.2 Series Part No. 12162833. Mating terminal: Delphi Part No. 12124075.

A pull up resistor is required between power and each output. Resistor value is dependent upon input voltage. See page 22 for recommendations.

Dimensions inches (mm)

All tolerances ± 0.005 (0.13) unless otherwise noted.

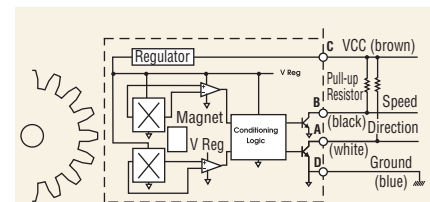
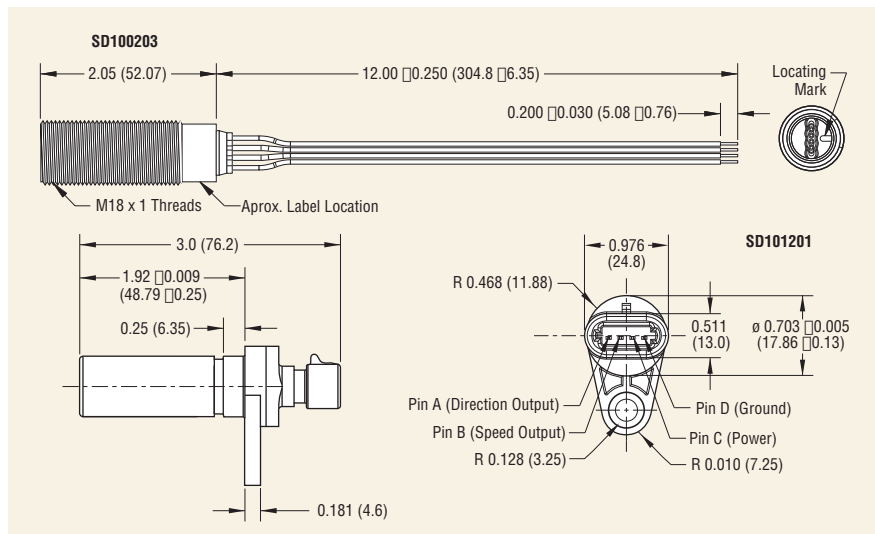

ANGULAR POSITION SENSOR

AN1 Series



Intrinsically Linear Angular Position Sensor

Features

- Patented non-contact angular position sensor
- Magnet/sensor orientation provides intrinsically linear output up to 100 degrees of electrical rotation (120 degrees mechanical rotation) without need for electrical compensation
- Provided with programmed output or end-user re-programmable to eliminate mechanical and process tolerances in your final assembly
- Adjustable rising or falling output slope with programmable offset, gain temperature compensation, and clamping voltage
- Return spring provides resistance to CCW motion
- Provided with EMI/ESD protection

- Fully encapsulated electronics to IEC 60529 IP67
- ILAPS® technology can be custom packaged to meet your exact requirements (minimum quantities apply)

Applications

- Throttle and valve position sensing
- User interface controls (vehicles, gaming)
- Pedal position sensing
- Implement position sensing
- Gear Selection
- Joystick position

Dimensions inches (mm)

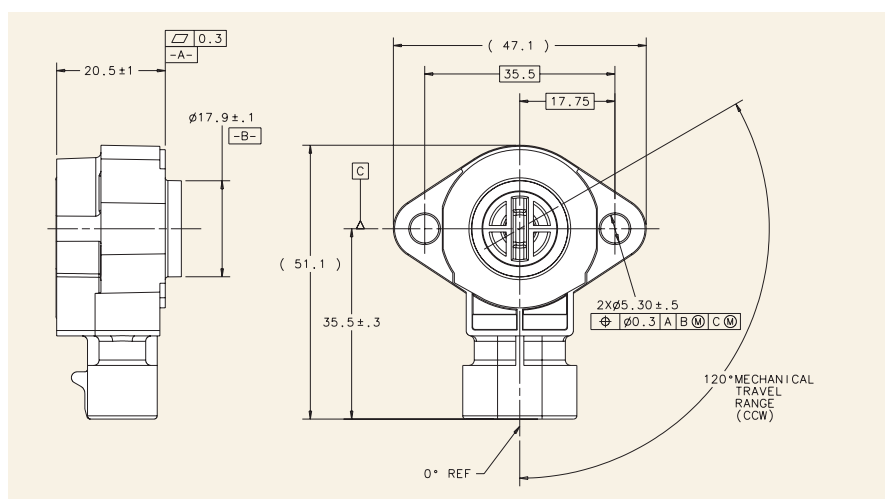

AN101101 120° Sensor Output

(Typically Based on 5V Supply)

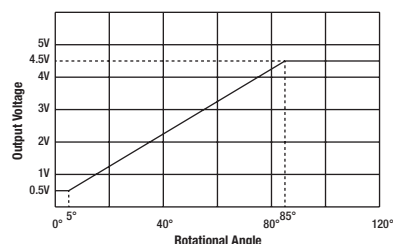

Mechanical Specifications

Mechanical Travel	120° CCW maximum rotational travel
Rotation Torque	0.12N-m max with return spring
Mass	12 grams
Life	+10 million full cycles
Dither (2° Travel)	+80 million cycles
Mating Connection	Connector: Packard metri-pack 150 12162185 Terminal: 12124075

Electrical Specifications

Effective Rotational Sensing Range	Maximum 100° electrical output
Input Voltage	5.0 V ± 10%
Input Current	10mA, max. @ 5VDC
Input Current, Output(s) Shorted to Ground	25mA, max. per output
Max Overvoltage	24VDC
Sensor Output @ 5VDC (Ratiometric to Input Voltage)	0.5V to 4.5V Max, programmable within 5% to 95% of the nominal voltage with positive or negative slopes
Output Linearity @ 5VDC	± 2%
Resolution	Analog
Response Time	.23mSEC
Bulk Current Injection	SAE J1113-4, 250kHz to 500MHz, 60mA/m
Conduction and Coupling	SAE J1113-12; ± 200V
Electronic Discharge	SAE J1113-13; ± 15kV
Radiated Immunity	SAE J1113-21; 10kHz to 18GHz, 100V/m
Immunity to Magnetic Fields	SAE J1113-22; 600uT AC Field, 5Hz to 2kHz, .2mT & 1mT DC Field
Immunity to AC Fields	SAE J1113-25, 15,000V/m
Radiated Emissions	SAE J1113-41; Class 4

Environmental Specifications

Vibration	10 G's peak, 20 Hz to 1000 Hz
Shock	20 G's, half sine pulse, 13 ms duration
Operating Temperature	-40°C to +125°C
Storage Temperature	-55°C to +135°C

THIN ANGULAR POSITION SENSOR

AN8 Series



Programmable, non-contact magnetic position sensors capable of continuous rotation

Features and Benefits

- Angular position with high tolerance for misalignment
- Provides non-contact angular position sensing and full 360° rotation
- 5VDC ratiometric device.
- Linear output over specific angular rotation ranges available on request
- Sealed design exceeds IEC 60529 IP67 standard for immersion
- Performs with AS500106 standard magnetic carrier
- Sensor can be programmed for use with custom magnets
- Custom programming option for rising or falling output slope with selectable offset, gain, clamp voltage
- PWM output option available for custom applications
- Provided with EMI/ESD protection to SAE J1113 standards
- Maximum operating temperature of 150°C (optional)
- No mechanical interface means no parts to wear out

Description

The sensor is applied by rotating a magnetic actuator close to the face of the sensor. Output voltage varies with angular position of the magnet relative to the sensor.

Optimal performance is achieved with Cherry's AS500106 magnetic actuator. Sensor kits including this standard magnet are available

Applications

- Throttle position sensor
- Replacement for smart bearings
- PRNDL switch for harsh environments
- Steer wheel position for drive by wire systems
- Pedal position sensor

Dimensions inches (mm)

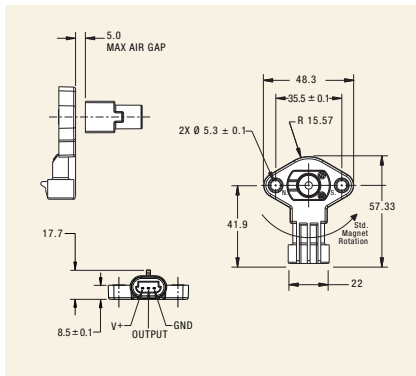

Note: See page 22 for dimensions on the AS500106 Mating Magnet Carrier.

Mechanical Specifications

Mechanical Travel	0 to 360 degrees (no stops)
Dither	No mechanical contact
Mating Connector	Connector: Delphi Metri-pak 150.2 12162185 Terminal: 12124075
Maximum Air Gap	5mm
Maximum Center-to-Center Offset	2mm (magnet to sensor)

Electrical Specifications

Effective rotational sensing range	0 to 360 degrees of rotation
Input Voltage	5.0 VDC ± 10%
Max Overvoltage	20 VDC reversed voltage -10 VDC
Output Current Range	8mA
Resolution	Analog
Conduction and Coupling	SAE J1113-12; ± 200V
Electronic Discharge	SAE J1113-13; ± 15kV
Immunity to Magnetic Fields	SAE J1113-21
Conducted Transient Emissions	SAE J1113-42
Radiated Emissions	SAE J1113-41; Class 4
Output Linearity (with supplied magnet)	± 2.5% Full Scale
Analog Output Slew Rate	200 V/ms
Accuracy	± 2%
Operating Temperature	-40 to 125°C (150°C max option)

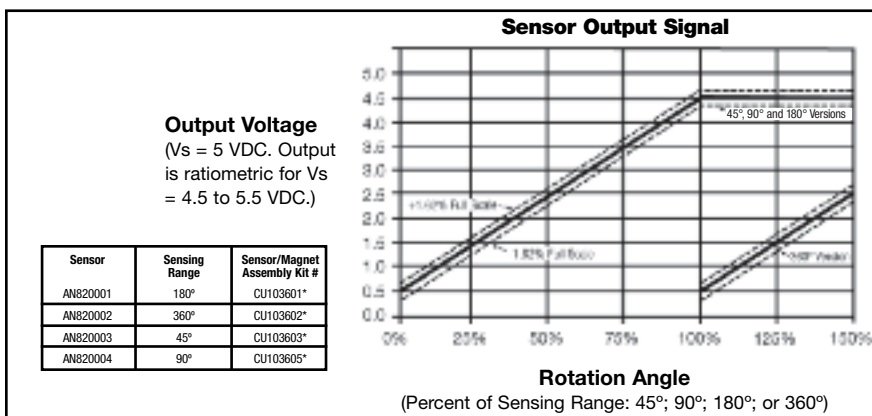

*Includes AN8 sensor and AS500106 magnetic actuator

MAGNETS AND

Interfacing



ACTUATOR MAGNET **AS101001**

Easy to install actuator magnet with threaded aluminum holder.

- South pole facing Alnico magnet
- Also available in the same package:
- **AS101002** with north pole facing Alnico magnet
 - **AS101003** with south pole facing samarium cobalt magnet

MAGNET CARRIER **AS500106**

- PPS Housing
- SmCo28 Magnet
- Recommended fastener: M4 Cap Screw
- Recommended torque: 3Nm (26.5 in. lbs.)

Current Sink Interfacing

3-Wire Sinking Interface

Sinking outputs are often used in negative logic applications, where a low signal is required for an active state. There, sinking outputs normally have current flowing into the device output lead when the device is active. Also called “open collector outputs,” sinking outputs are compatible with any logic family since a wide voltage range may be used for Vcc. Furthermore, the voltage level used to power the Hall effect assembly may differ from the pull-up resistor to which it is attached. The external pull-up resistor connected between the output and Vcc is required for proper operation. With the resistor connected as shown, the output will be “pulled up” to Vcc when off and (approximately) to ground when on.

Recommended pull-up resistor values are as follows:

Volts dc	5	9	12	15	24
Ohms	1k	1.8k	2.4k	3k	3k

Sensor Series	Connector Type	Connection Grid				
		Vcc	Output	Ground	Direction	Speed
MP	12mm circular	1	4	3	N/A	N/A
	Wire Lead	Brown	Black	Blue	N/A	N/A
	Wire Lead	Red	Green	Black	N/A	N/A
GS	12mm circular	1	4	3	N/A	N/A
	Wire Lead	Brown	Black	Blue	N/A	N/A
	Delphi	A	B	C	N/A	N/A
VN	Pin	1	3	2	N/A	N/A
	Wire Lead	Red	Green	Black	N/A	N/A
SD	Wire Lead	Brown	—	Blue	White	Black
	Delphi	C	—	D	A	B

Dimensions inches (mm)

All tolerances ± 0.005 (0.13) unless otherwise noted.

AS101001

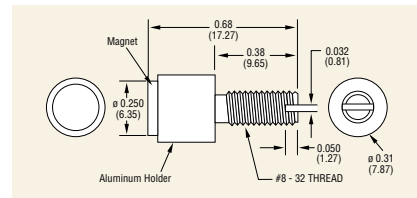

AS500106

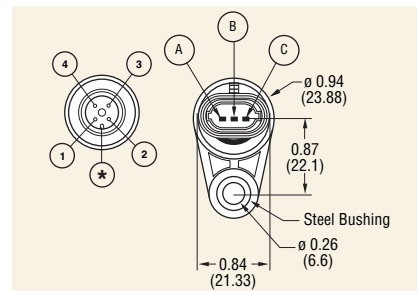
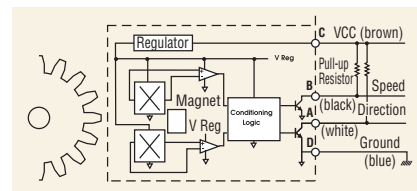
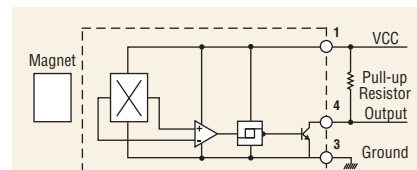
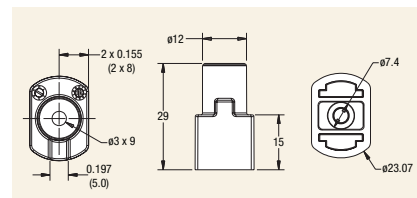

REED AND GEARTOOTH

Sensor Operation

MP Series Reed Sensors

A Reed Sensor is an omnipolar, magnetically activated switch. It can be approached by a magnet from any angle, with either pole. Several possible operating methods are shown at right.

Perpendicular Magnet Travel

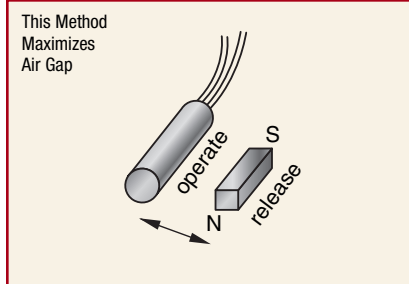

Parallel Magnet Travel

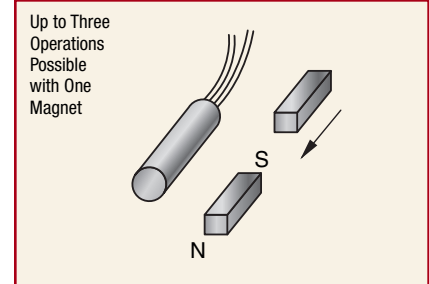

Nose-To-Nose Activation

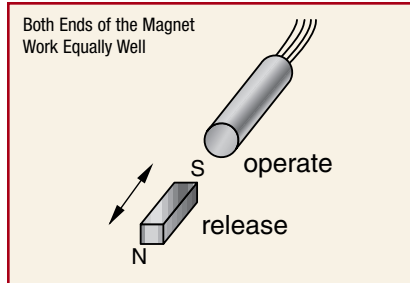

Rotational Magnet Travel

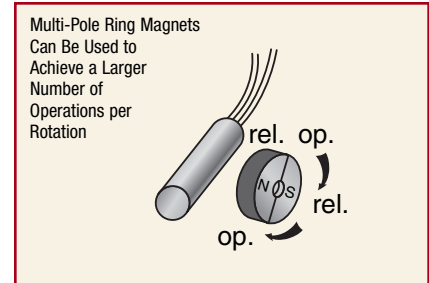

Operating a Speed Sensor

Although commonly called a geartooth sensor, a solid-state speed sensor can detect the motion of various ferrous objects with some type of discontinuous surface.

Examples of appropriate targets include:

- Sprockets
- Bolt Heads
- Roller Chains
- Cavities in a Smooth Surface

Solid-State Speed Sensor

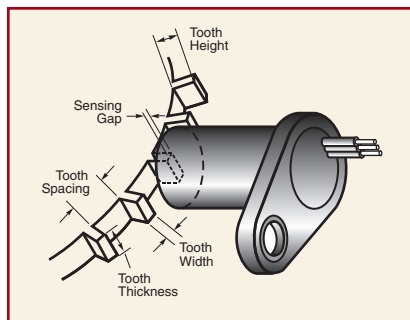

For best results, we recommend targets made from low carbon cold rolled steel. Other factors that influence sensor performance include geartooth height and width, space between teeth, shape of the teeth and thickness of the target. As a general guideline, consider a target with the following minimum parameters:

Tooth Height	Tooth Width	Distance Between Teeth	Target Thickness
.200"	.100"	.400"	.250"

Cherry's solid-state magnetic position sensors also make excellent speed sensors when coupled with a rotating ring magnet. Advantages of this approach include:

- lower sensor cost
- larger airgaps and
- absolute zero-speed sensing.

Position Sensor with Ring Magnet

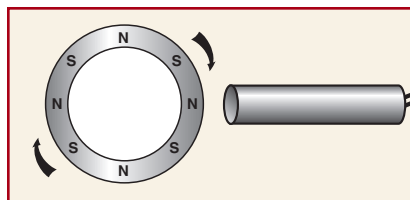

CUSTOM DESIGN CAPABILITIES

Sensors



Magnetic Speed and Direction Sensor

Features

- Capable of sensing direction of rotation and speed of a magnetic ring target
- Eliminates the hurdles encountered with fine pitch direction detection
- Adjustable housing with integral LED ease installation by providing indication of output
- Operating temperature range: -40°C to +150°C

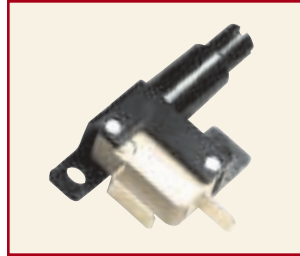

Magnetic Inertial Imbalance Sensor

Features

- The device consists of a snap action switch where attraction forces of a magnet hold the actuator mass away from the switch actuator
- Increasing G-force on the device overcomes the magnetic attraction force and activates the switch
- Device is magnetically adjusted to switch at specific acceleration levels along the actuation axis. Typically around 3 to 4 times the force of gravity
- UL recognized, CSA approved
- Operating temperature range: -40°C to +85°C



Rugged Rotary Encoder

Features

- Magnetic ASIC-based incremental rotary encoder provides speed, location and direction indication from 2 channel quadrature output
- Significant life and environmental performance advantages over optical sensors
- Reliable 1024 pulses per revolution
- Designed for hostile environments:
 - Operating temperature range: -40°C to 125°C
 - 200G shock load
 - Vibration tested to 75G, 50 to 2000Hz
 - Sealed to IEC529 IP68 for dust and water protection
- Shaft loading: 80 lbs. radial, 20 lbs. axial

For additional information on Cherry sensors, or our complete line of switch products, call or visit our web site today.

Cherry Electrical Products

11200 88th Avenue
Pleasant Prairie, WI 53158

www.cherrycorp.com

Phone: 800 285 0773

262 942 6500

Fax: 262 942 6566

Cherry Corporation disclaims any warranties of merchantability, fitness for a particular purpose or noninfringement. While Cherry Corporation intends for this information to be accurate, there may be inadvertent technical and typographical errors, for which Cherry Corporation assumes no liability.